A Review on Effect of Wavelength Assignment on Passive Optical Networks

Er. Ankita Mittal

Assistant Professor Electronics & Communication Engg. Dept.
Galaxy Global Educational Trust Group of Institutions,
Dinarpur, Ambala, India
ankita.mittal@galaxyglobaledu.com

Balraj Singh

Electronics & Communication Engg. Dept.
M.Tech Scholar of Galaxy Global Educational Trust Group of Institutions,
Dinarpur, Ambala, India
bsmehla15@gmail.com

Abstract: *In this paper, Effect of wavelength assignment on Passive optical networks has been reviewed. In WDM networks, each edgenode (EN) has its own light sources, and optical channels, called lightpaths, are established by using optical carriers generated from laser diodes (LDs) at the source. However, such networks will suffer from the need for complicated wavelength management. While designing WDM system is explored, it considers the physical layer impairments incurred by non-ideal optical transmission media that accumulates along the optical path. For very high transmission speed, dispersion developed a considerable degradation factor and in this work concentrated on the effects of dispersion on fiber design parameters such as bandwidth, delay and bit rate. The dependence of carrier RB suppression on DI's extinction ratio (ER) and optical carrier's line width is also theoretically analysed. In this research work, the issue of connection provisions and performance analysis in WDM network ensuring the quality of service requirement of the connection requests from the client in the network in optical networks. The main relations between different parameters of optical network unit (ONU) are also studied.*

Keywords: *Passive Optical Networks, WDM-PON, Wavelength Allocation, Rayleigh Scattering Parameters.*

1. INTRODUCTION

FORESEEING the rapidly growing demand for multimedia services and the trend of service convergence, the wavelength-division-multiplexed (WDM) passive optical network (WDM-PON) is a promising technology to provide next-generation broadband access that requires large dedicated symmetric bandwidth and upgrading flexibility. An optical network is a type of data communication network built with optical fiber technology. It utilizes optical fiber cables as primary communication medium for converting data as light pulses between sender and receiver nodes. Wavelength division multiplexing (WDM) technology is a strong candidate for next generation high performance networks because it provides large bandwidth, low bit error rate, low control requirements and low cost. WDM knowledge has provided tremendous bandwidth for optical fibers by allowing simultaneous transmission of traffic on many non-overlapping channels (wavelengths) in an optical fiber [1]. In a wavelength-routed WDM system, end users communicate with one another via all-optical WDM channels, which are referred to as lightpaths[1].

A **passive optical network (PON)** is a point-to-multipoint, fiber to premises system architecture in which unpowered optical splitters are used to enable a single optical fiber to serve multiple premises, typically 16-128. A PON consists of optical line terminal (OLT) at the service provider's central office and a number of optical network units (ONUs) near end users. Passive optical network (PON) has advantages in high bandwidth capacity, also low operation and maintenance rate, and has been measured as a promising access network solution and widely deployed [3]. Various PONs, e.g., Ethernet PON (EPON) and Gigabit-capable PON (GPON), use time division multiplexing (TDM) technique to enable multiple users to share a common wavelength bandwidth resource in PON, and they are called as TDM PONs. WDM technology enables network operators to continuously increase

the capacity of their networks. Undoubtedly, WDM will continue the key technology to satisfy the ever increasing demand for more bandwidth within the next years [3].

Currently, the optical network technology holds the key to the next-generation networks. Wavelength-division-multiplexing (WDM) networks have emerged as a promising candidate for next-generation networks providing large available bandwidth. A WDM network contains WDM switches connected by fiber optical links. In each link, many wavelengths are available. In a dense wavelength-division-multiplexing (DWDM) network, a link can have hundreds of wavelengths. This number can go much higher in the near future. Transmissions in different wavelengths on the same link do not interfere with each other. Each wavelength can carry a huge amount of traffic. In multi-hop network design, the selection of a proper logical topology is followed by the wavelength assignment process. The simplest scheme for wavelength assignment assigns one wavelength channel to each of the logical links. An alternative scheme that requires a smaller number of wavelengths and transmitters is the assignment of one wavelength channel per end-node. If number of wavelength channels in the network is smaller than the number of end-nodes, these schemes will fail. The carrier RB light towards OLT, with a fine spectrum, can be effectively suppressed by an optical notch filter. While carrier regeneration decreases number of wavelengths, the signal quality of carrier must be considered because it becomes slightly worse after regeneration. If signal quality becomes unacceptable after several regenerations, its wavelength should not be reprocessed anymore in order to eliminate communication fault. i.e., allowable number of carrier regenerations per wavelength should not be exceeded [6].

The paper is organized as follows. In section II, we discuss related work with the wavelength allocation scheme. In Section III, It describes types of PON. In Section IV, it describes the system architecture and analyse the different parameters of Rayleigh scattering in impairing the upstream signal. Finally, conclusion is given in Section V.

2. RELATED WORK

In literature, several proposed Rayleigh noise reduction in wavelength-division-multiplexed passive optical network (WDM-PON). Then they propose and demonstrate a novel scheme to effectively suppress the carrier RB in carrier-distributed WDM-PONs. By simply replacing upstream modulation format of conventional on-off keying with differential phase-shift keying (DPSK), the system tolerance to carrier RB is substantially enhanced by 19 dB, as carrier RB can be considerably rejected by the notch filter-like destructive port of the delay-interferometer at the optical line terminal, which is used instantaneously to demodulate the upstream DPSK signal. As no thoughtful spectral up-shifting is required in this scheme, neither other modulator nor complicated modulation/demodulation circuit is needed at ONU/OLT. In terms of optical notch filter used to reduce RB light, the standard DI used in the future scheme is also more favourable than the non-standard filters [2].

Authors propose and demonstrate a novel colourless optical transmitter based on all-optical wavelength conversion using a reflective semiconductor optical amplifier for upstream transmission in wavelength-division-multiplexed passive optical systems. The proposed colourless optical transmitter for the optical network unit is composed of an electro-absorption modulated laser, a photosensitive coupler, and an RSOA. Through cross-gain modulation in RSOA, the upstream data from the EML pump light are imposed onto a continuous-wave probe light provided from the central office. An optical delay interferometer at CO tailors the chirp of the upstream signal to improve the bandwidth of the system and dispersion tolerance. The proposed optical transmitter is based on the fast gain recovery of the RSOA governed by carrier-carrier scattering and carrier-phonon relations [15]. End-to-end real-time optical orthogonal frequency-division multiple-access (OOFDMA) passive optical networks (PONs) with adaptive dynamic bandwidth allocation (DBA) and colourless optical network units (ONUs) are experimentally established, for the first time. Next generation Passive Optical Network (PON) technology has been evolving to consolidate the metro and access networks in order to offer enhanced capacity, high split ratio and compact deployment cost per subscriber. However, transmission of signals to long distances up to 100 km leads to increased propagation delay whereas high split ratio may lead to long cycle times resulting in large queue occupancies and long packet delays. In this article, they current a delay-constrained admission control mechanism and adapt this scheme to our previously proposed bandwidth allocation technique. This paper investigates problem of dynamic wave length allocation and fairness control in WDM optical networks. An f network topology, with a two-hop path network, is studied for mainly three classes of traffic. Each class corresponds to a source & destination pair. For each class call inter-arrival & holding

times remain studied. The objective is to find a wavelength allocation policy to maximize the weighted sum of users of all the three programs. In a conventional WR network, an entire wavelength is assigned to a given connection. This can lead to lower channel utilization when individual sessions do not need the entire channel bandwidth [7].

3. TYPES OF PON

A PON system uses the passive splitter that takes one input and splits it to "broadcast" signals to many users.

3.1 Broadband Passive Optical Network

For many network operators, an optical access network is the ultimate target for the delivery of fixed broadband services. The BPON is accepted as a cost-effective fibre to the home solution well-suited to the future needs of broadband services. A major feature of the BPON is that 32 customers can be concentrated on a single fibre to the central office using a simple passive optical splitter. Since optical splitter requires no electrical power, it removes a major cost and maintenance element in today's digital loop carrier systems. The BPON supports a bit rate of 622 or 155 Mbit/s in the downstream and upstream direction, which is shared by the users through time division multiplexing. Broadband passive optical network standards are based on the G.983 series of ITU-T Recommendations that specify ATM as the transport and signalling protocol. By improving the optical budget on the BPON fibre, up to 128 or 256 homes could be "passed" by a single high split. Up to 64 of these homes could be connected, which is the maximum number of ONUs (Optical Network Unit) that can be identified by a G.983.1 compliant system. In preparation for higher service penetrations, optical splitter in the outside network would be limited to 8, 16 or 32-way split. Since exchange carriers have an extensive embedded ATM switching infrastructure, these carriers are using BPON technology to deploy the fiber-to-the-premises networks. By improving the optical budget on the BPON fibre, up to 128 or 256 homes could be "passed" by a single high split. In preparation for higher service penetrations, optical splitter in the outside network would be limited to 8, 16 or 32-way split [8].

3.2 Ethernet Passive Optical Network

Data traffic is increasing at an unprecedented rate. Sustainable data growth rate of over 100% per year has been observed since 1991. There were periods when a combination of economic and technological factors resulted in even larger growth rates, e.g., 1000% increase per year in 1995 and 1996. Ethernet PON (EPON) is a PON-based network that carries data traffic encapsulated in Ethernet frames (defined in IEEE 802.3 standard). It uses a standard 8b/10b line coding (8 user bits encoded as 10 line bits) and operates at standard Ethernet speed. Since this method encapsulates and transports data in Ethernet frames, it is easy to carry IP packets over an Ethernet link. This scheme thus simplifies the interoperability of metro and wide area network assets with installed Ethernet LANs compared to the use of BPON technology. Ethernet has become a universally accepted standard, with over 300 million port deployments worldwide, offers staggering economies of scale. High-speed Gigabit Ethernet deployment is widely accelerating and 10 Gigabit Ethernet products are becoming available [9].

Ethernet, which is easy to scale and manage, is winning new grounds in MAN & WAN. Considering the fact that 95% of LANs use Ethernet, which clears that ATM PON may not be the best choice to interconnect two Ethernet networks. One EFM option uses an EPON architecture that follows the standard PON layout, which has one main feeder line going to an optical splitter. Up to 32 distribution branches leave the splitter and interface to ONTs. The IEEE 802.3 standard defines two basic configurations for an Ethernet network. In one configuration, it can be organized over a shared medium using the Carrier Sense Multiple Access with Collision Detection protocol. In another configuration, stations may be connected through a switch using full-duplex point-to-point links. The Properties of EPON are such that it cannot be considered either a shared medium or a point-to-point network; rather, it is a combination of both. In downstream direction, Ethernet frames conveyed by OLT pass through a $1:N$ passive splitter and reach each ONU. N is typically between 4 and 64. This behaviour is similar to a shared network. Because Ethernet is broadcast by nature, in the downstream direction (from network to user), it fits perfectly with Ethernet PON architecture: packets are broadcast by the OLT and extracted by their destination ONU based on the media-access control address. In the upstream direction, due to the directional properties of a passive optical combiner, data frames from ONU will only reach the OLT, and no other ONUs. In that sense, in upstream direction, the behaviour of EPON is similar to that of a point-to-point architecture.

3.3 Gigabit Passive Optical Network

The growing demand for higher speeds in the access network spawned the idea of developing a PON with capabilities beyond those of the BPON and EPON architectures. A major aim of this idea was to develop a versatile PON with a frame format that could transmit variable-length packets efficiently at gigabit per second rates. The FSN group started such an effort in April 2001. The result was the ITU-T recommendation series G.984.1 through G.984.4 for a gigabit PON.

The GPON standard is defined in the International Telecommunication Union Telecommunication Standardization Sector (ITU-T) G.984.x series of Recommendations sponsored by the full service access network (FSAN). Several upstream and downstream rates up to 2.48832 Gb/s are specified in the standard. Here we consider the 1.24416 Gb/s upstream rate to make it comparable with EPON. The GPON protocol is based on the standard 125 μ s (~19,440 bytes at 1.24416 Gb/s) periodicity used in the telecommunications industry. This periodicity provides certain efficiency advantages over EPON, as messages (control, buffer report, and grant messages) can efficiently be integrated into the header of each 125 μ s frame.

Within GPON each Ethernet frame or frame fragment is encapsulated in a general encapsulation method (GEM) frame including a 5-byte GEM header. The network layout for a GPON follows that of a standard PON concept. It also retains much of the same functionality characteristic of BPON and EPON schemes, such as DBA and the use of operations, administration, and maintenance (OAM) messages [10].

4. SYSTEM ARCHITECTURE AND RAYLEIGH PARAMETERS

4.1 System Architecture

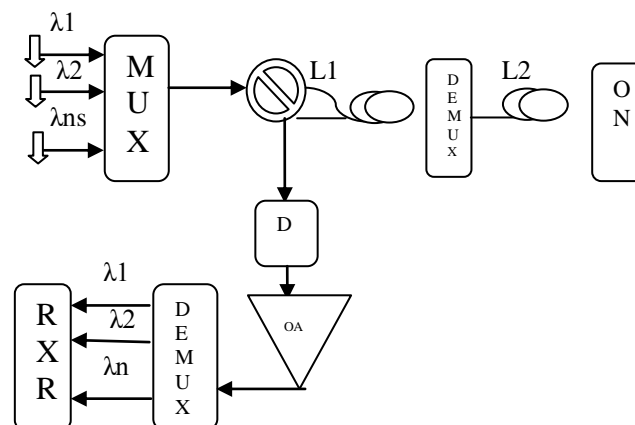

Figure 1. Proposed system architecture to suppress Rayleigh sound. OA: opticalamp, D: delay-interferometer, MUX: Multi-plexer, DEMUX: De-multiplexer, ON: Optical network Unit.

Fig. 1 shows the proposed architecture of a WDM-PON. As downstream plus upstream signals are transmitted over different wavelength bands in the carrier-distributed WDM-PON, RB from upstream signal will not affect with the downstream signal, and vice versa. Passive optical systems have high bandwidth Point-to-Multipoint optical fiber network based on the Asynchronous Transfer Mode (ATM), Ethernet or TDM. PONs relies on light waves for data transfer. Only passive components are used such as optical fiber, splices and circulators etc. PONs reduces the fiber deployment in both the local exchange office and local loop. The PON is an access network based on optical fiber [11]. It is designed to provide virtually unlimited bandwidth to subscriber [11].

The multi-wavelength optical carriers for upstream transmission are generated by continuous-wave (CW) lasers as centralized light sources, and then multiplexed through an AWG. After transmission in a feeder fiber with a length of L1, optical carriers are wavelength routed toward different ONUs, by another AWG at the remote node (RN). The length of the distribution fiber (between RN and ONU) is L2. At ONU, CW light is first amplified and then modulated driven by differentially pre-coded upstream data, before being sent back to OLT. Due to DI's periodic frequency response, all upstream channels could be simultaneously demodulated by a common DI at the OLT. Note that only destructive port of the DI can be used for upstream demodulation and carrier RB suppression simultaneously due to its notch filter-like frequency response [4].

4.2 Components Used

4.2.1 Transponders

Transponder is the basic element for transmission and reception of optical signal from the channel. A transponder is generally characterized by the maximum bit rate it can handle with and the maximum distance the optical pulse can travel without degradation. Transponders convert an optical signal from one wavelength to an optical pulse with another wavelength. Another important function of transponder device is the conversion of broadband signal to a signal associated with specific wavelength by optical to electrical to optical conversion.

For detection purposes, it uses photo-detector. This photo-detector generates an electrical current proportional to the incident optical power. Photo-detectors are made of semiconductor materials. Photons incident on a semiconductor are absorbed by electrons in the valence band. As a result, these electrons acquire higher energy and are excited into the conduction band, leaving behind a hole in valence band. When an outer voltage is applied to the semiconductor, these electron-hole pairs give rise to an electrical current, termed the photocurrent [12].

4.2.2 Wavelength Cross Connect

Wavelength cross connect is a switching device whose function is to switch or connect any wavelength from the input port to any one of the out port in the fiber. The functioning is completely in optical domain. An OXC with N input and N output ports capable of handling W wavelengths per port can be thought as W independent $N \times N$ optical switches. The polarization-independent Acoustic optical tunable filters (AOTF) can be used as a two input, two-output dynamic wavelength cross connect [12].

4.2.3 Couplers

A passive optical network employs a passive (not requiring any power) device to split optical signal (power) from one fiber into several fibers and reciprocally, to combine the optical signals from multiple fibers into one. This device is an optical coupler. In simplest form, an optical coupler consists of two fibers fused together. Signal power received on input port is split between both output ports. The splitting ratio of splitter can be controlled by the length of the fused region and therefore is a constant parameter. A directional coupler is used to combine and split signals in an optical network [13].

4.2.4 Circulators

A circulator is similar to isolator, except that it has multiple ports, typically three or four. In 3-port circulator, an input signal on port 1 is sent out on port 2, a signal on port 2 is sent out on port 3, plus an input signal on port 3 is sent out on port 1. Circulators are useful to construct optical add/drop elements. Circulators operate on the same principles as isolators.

4.2.5 Multiplexers

Optical Add-Drop multiplexer is a device which is capable to add or drop one or more wavelengths from the existing WDM system. There are three important domains for an OADM- optical multiplexer, de multiplexer and a method to reconfigure the path between multiplexer and de multiplexer. Demultiplexers and multiplexers can be cascaded to realize static wavelength cross connects. The device routes signals from an input port to an output port based on the wavelength.

4.2.6 Optical Amplifiers

An optical amplifier is a device which amplifies the optical signal directly without optical to electrical conversion i.e., all functions occurs in optical domain. In optical fiber, the light pulse itself is amplified. Optical amplifiers provide high gain and low noise for the optical signal; it has importance in the overall bandwidth provided by WDM system. Optical amplifiers offer several advantages over regenerators. On one hand, regenerators are specific to the bit rate and modulation format used by the communication system. On the other hand, optical amplifiers are insensitive to the bit rate or signal formats. Thus a system using optical amplifiers can be more easily upgraded. Thus a system using optical amplifiers can be more easily upgraded, for example, to a higher bit rate, without replacing the amplifiers. In contrast, in a system using regenerators, such an upgrade would require all the regenerators to be replaced. Furthermore, optical amplifiers have fairly large gain bandwidths. Thus

optical amplifiers have become essential components in high-performance optical communication systems [14].

4.2.7 Interferometers

An interferometer is a device that makes use of two interfering paths of different lengths to resolve different wavelengths. Mach interferometers are typically constructed in integrated optics and consist of two 3 dB directional couplers interconnected through two paths of differing lengths. Interferometers are useful as both filters and demultiplexers. Even though there are better technologies for making narrow band filters, for example, dielectric multi-cavity thin-film filters, MZI are still useful in realizing wide band filters. Narrow band interferometers filters are fabricated by cascading a number of stages.

4.2.8 Switches

Optical switches are used in optical networks for a variety of applications. The different applications require different switching times and number of switch ports. One application of optical switches is in the provisioning of lightpaths. In this application, switches are used inside wavelength cross-connects to reconfigure them to support new lightpaths. Switches are also important components in high-speed optical packet-switched networks. In these networks, the switches are used to switch signals on a packet-by packet basis.

For this application, the switching time must be much smaller than packet duration, and large switches will be needed. Yet another use for switches is as external modulators to turn on and off the data in front of a laser source. In this case, switching time must be a small fraction of the bit duration. The extinction ratio of an on-off switch is the ratio of the output power in the on state to the output power in off state. This ratio should be as large as possible. The insertion loss of a switch is the fraction of power (usually expressed in decibels) that is lost because of the presence of the switch and must be as small as possible. The switch needs to have a readout capability wherein its current state can be monitored. This is important to verify that the right connections are made through the switch [15].

4.3 Rayleigh Parameters

Rayleigh scattering named after the British physicist Lord Rayleigh, is elastic scattering of light or other electromagnetic radiation by particles much smaller than the wavelength of light. After the Rayleigh scattering the state of material remains unchanged, hence this rayleigh scattering is also said to be a parametric process. These particles may be individual atoms or molecule. It can occur when light travels through transparent solids and liquids, but it is most prominently seen in gases. Rayleigh scattering results from electric polarizability of particles. The oscillating electric field of a light wave acts on the charges within a particle, causing them to move at same frequency.

Rayleigh crosstalk is induced by the beating between the upstream signal and the in-band RB noise towards the OLT. Two types of RB exist: carrier RB and signal RB. The carrier RB arises from the CW carrier delivered to ONU, whereas the signal RB is the back reflection of the upstream signal, which is further amplified and modulated at ONU before transmitting to the OLT, along with the upstream signal. By calculating the power ratio between two types of RB, we can find out their different contributions in the upstream Rayleigh noise[5].

We first calculate the power of carrier RB. The mean intensity of the carrier RB produced in the feeder fiber is given by [12]:

$$P_{cb1} = \frac{P_c}{R1} \tag{1}$$

Where P_c is the power of optical carrier incident to the feeder fiber, and $R1$ is RB-induced return loss of the feeder fiber that is given by equation(2):

$$R1 = \frac{2}{S(1 - e^{-2\alpha p L1})} \tag{2}$$

With S , αp being the recapture factor, and fiber attenuation factor in units of km respectively. Now, mean intensity of the carrier RB generated in the distribution fiber is given by equation (3):

$$P_{cb2} = \frac{P_c}{(\alpha 1 \alpha A)^2 R2} \tag{3}$$

Where α_1, α_A are the insertion loss of the feeder fiber and the AWG at RN in linear scale, respectively, and is RB induced return loss of the distribution fiber. Now, α_1 and R2 are given by equation (4) & (5):

$$\alpha_1 = e^{\alpha p L_1} \quad (4)$$

$$R_2 = \frac{2}{S(1 - e^{-2\alpha p L_2})} \quad (5)$$

Similarly, we can calculate the power of signal RB at port 2 of the OLT optical circulator. The mean intensity of the signal RB generated in the feeder fiber is given by equation (6):

$$P_{sb1} = \frac{P_c * G_{onu}^2}{R_1 * \alpha_1^2 (\alpha_A * \alpha_2)^4} \quad (6)$$

With α_2 and G_{onu} being the insertion loss of the distribution fiber and the ONU gain, respectively. The ONU gain is defined as the power ratio between the output and the input signals at ONU. α_2 is further given by equation (7):

$$\alpha_2 = e^{\alpha p L_2} \quad (7)$$

The mean intensity of signal RB generated in the distribution fiber is given by equation (8):

$$P_{sb2} = \frac{P_c * G_{onu}^2}{R_2 * (\alpha_1 * \alpha_A * \alpha_2)^2} \quad (8)$$

5. CONCLUSION

This paper reviewed the wavelength assignment and their effect in WDM network with optical carrier regeneration. The wavelength transfer problem was transformed into the vertex colouring problem. An optical delay interferometer at central office tailors the chirp of the converted upstream signal to improve the system bandwidth and the dispersion tolerance. The bandwidth of system can be increased by increasing the capacity of the system. The capacity of system can be increased by increasing the number of users without disturbing the working of another user.

REFERENCES

- [1] G. K. Chang, A. Chowdhury, Z. S. Jia, H. C. Chien, M. F. Huang, J. J. Yu, and G. Ellinas, "Key technologies of WDM-PON for future converged optical broadband access networks [invited]," *J. Opt. Commun. Networks.*, vol. 1, pp. C35–C50, 2009.
- [2] N. J. Frigo, P. P. Iannone, P. D. Magill, T. E. Darcie, M. M. Downs, B. N. Desai, U. Koren, T. L. Koch, C. Dragone, H. Presby, and G. E. Bodeep, "A wavelength-division multiplexed passive optical network with cost-shared components," *IEEE Photon. Technology Lett.*, vol. 6, no. 11, pp. 1365–1367, Nov. 1994.
- [3] M. Feuer, M. Thomas, and L. Lunardi, "Backreflection and loss in fiber loopback networks," *IEEE Photon. Technology Lett.*, vol. 12, no. 8, pp. 1104–1108, Aug. 2000.
- [4] T. H. Wood, R. A. Linke, B. L. Kasper, and E. C. Carr, "Observation of coherent Rayleigh noise in single-source bidirectional optical fiber systems," *J. Lightw. Technology*, vol. 6, no. 2, pp. 346–352, Feb. 1988.
- [5] P. T. Legg, M. Tur, and Andonovic, "Solution paths to limit interferometric noise induced performance degradation in ASK/direct detection lightwave networks," *J. Lightw. Technology*, vol. 14, no. 9, pp. 1943–1953, Sept. 1996.
- [6] E. Wong, "Current and next-generation broadband access technologies," presented at Opt. Fiber Commun./National Fiber Opt. Eng. Conf., Los Angeles, CA, 2011, Paper NMD1.
- [7] N. Suzuki, K. Nakura, T. Suehiro, S. Kosaki, and Nakagawa, "Over-sampling based burst-mode CDR technology for high-speed TDM-PON systems," presented at the Opt. Fiber Commun./National Fiber Opt. Eng. Conf., Los Angeles, CA, 2011, Paper OTh3.
- [8] U. Hilbk, T. Hermes, J. Saniter, and F. Westphal, "High capacity WDM overlay on a passive optical network," *Electronic Lett.*, vol. 32, no. 22, pp. 2162–2163, 1996.
- [9] E. Wong, K. L. Lee, and T. B. Anderson, "Directly modulated self-seeding reflective semiconductor optical amplifiers as colourless transmitters in wavelength division multiplexed passive optical networks," *J. Lightw. Technol.*, vol. 25, no. 1, pp. 67–74, 2007.

- [10] I. Chlamtac, A. Ganz, and Karmi, "Lightpath communications: an approach to high bandwidth optical WAN's," IEEE Trans. Communication, vol. 40, no. 7, pp. 1171–1182, July 1992.
- [11] M. Matsuura and E. Oki, "Multi-carrier distributed WDM ring network based on reconfigurable optical drop-add-drop multiplexers and carrier wavelength reuse," in IEEE ICC, Cape Town, South Africa, 2010.
- [12] R. D. Der., y. j. Jhong, Delay-Constraint Survivable multicast Routing problem on WDM Networks," Communications and Networks in China, 2010.
- [13] B. Ramamurthy., Mukherjee, "Wavelength conversion in WDM networking,"IEEE Journal on Selected Areas in Commun., vol. 16, no. 7, pp. 1064–1073,1998.
- [14] P. J. Urban, A. M. J. Koonen, G. Khoe, and H. Waardt, "Interferometric crosstalk reduction in an RSOA-based WDM passive optical network," J. Lightw. Technology, vol. 27, no. 11, pp. 4943–4953, Nov. 2009.
- [15] T. Yoshida, S. Kimura, H. Kimura, K. Kumozaki, and T. Imai, "A newfiber 10-Gb/s optical loopback method using phase modulationfor WDM optical access networks," J. Lightw. Technology, vol. 24, no. 2,pp. 786–796, Feb. 2006.

AUTHOR'S BIOGRAPHY



Balraj Singh student M.Tech. I have passed B.Tech(ECE) from Technology Education & Research Integrated Institutions,Kurukshetra,India in 2011 and presently a student of M.Tech ECE final year at Galaxy Global Educational Trust Group of Institutions,Dinarpur,Ambala,India